

**Last name, first name:** \_\_\_\_\_

**Company address:** \_\_\_\_\_

\_\_\_\_\_

\_\_\_\_\_

**Phone:** \_\_\_\_\_

**Fax:** \_\_\_\_\_

**E-mail-address:** \_\_\_\_\_

**Invoice address:** \_\_\_\_\_

\_\_\_\_\_

\_\_\_\_\_

**Training company:** \_\_\_\_\_

**Trainer** \_\_\_\_\_

---

## **Foundation Level Sample Exam**

**SET A (V.2.1) – GTB edition –**

---

---

**CTFL Syllabus Version V.4.0**

---

**ISTQB® Certified Tester Foundation Level**

## Legal

Copyright © 2023 International Software Testing Qualifications Board (hereinafter called ISTQB®). All rights reserved.

The authors transfer the copyright to the International Software Testing Qualifications Board (hereinafter called ISTQB®). The authors (as current copyright holders) and ISTQB® (as the future copyright holder) have agreed to the following condition of use:

Any ISTQB® Member Board may translate this document.

The ISTQB® Examination Working Group is responsible for this document.

ISTQB® Exam Working Group 2023

## Acknowledgements

This document was produced by a core team from ISTQB®: Laura Albert, Wim de Coutere, Arnika Hryszko, Gary Mogyorodi, (technical reviewer), Meile Posthuma, Gandhinee Rajkomar, Stuart Reid, Jean-François Riverin, Adam Roman, Lucjan Stapp, Stephanie Ulrich, Yaron Tsubery and Eshraka Zakaria.

The core team thanks the review team: Amanda Alderman, Alexander Alexandrov, Jürgen Beniermann, Rex Black, Young jae Choi, Nicola De Rosa, Klaudia Dussa-Zieger, Klaus Erlenbach, Joëlle Genois, Tamás Gergely, Dot Graham, Matthew Gregg, Gabriele Haller, Chinthaka Indikadahena, John Kurowski, Ine Lutterman, Isabelle Martin, Patricia McQuaid, Dénes Medzihradzsky, Blair Mo, Gary Mogyorodi, Jörn Münzel, Markus Niehammer, Ingvar Nordström, Fran O'Hara, Raul Onisor, Dénes Orosz, Arnd Pehl, Horst Pohlmann, Nishan Portoyan, Ale Rebon Portillo, Stuart Reid, Ralf Reissing, Liang Ren, Jean-Francois Riverin, Lloyd Roden, Tomas Rosenqvist, Murian Song, Szilard Szell, Giancarlo Tomasig, Joanne Tremblay, François Vaillancourt, Daniel van der Zwan, André Verschelling and Paul Weymouth.

## Revision History

Version	Date	Remarks
1.0	12.04.2023	Release version
2.1	15.10.2023	Revision by GTB AG Exam (arrangement of questions changed, roman type questions eliminated, questions replaced and modified), revision after BETA reviews by GTB members, TAG and university lecturers.

## Introduction

This is a sample exam. It helps candidates to prepare for the actual certification exam. Questions are included whose structure, layout and format are like a regular ISTQB®/ GTB Certified Tester Foundation Level exam. It is strictly forbidden to use the exam questions as content of a certification exam.

- 1) Any individual or training provider may use this sample exam in a training course if ISTQB® is acknowledged as the source and copyright holder of the sample exam.
- 2) Any individual or group of individuals may use this sample exam as the basis for articles, books or other derivative writings if ISTQB® is acknowledged as the source and copyright holder of the sample exam.
- 3) Any national board recognized by ISTQB® may translate this sample exam and make it publicly available if ISTQB® is acknowledged as the source and copyright holder of the sample exam.
- 4) Exactly one correct solution is expected for almost every question. The exceptions explicitly mention the possibility of multiple answers.

## Exam notes

Number of questions: 40

Duration of the exam: 60 minutes

Total score: 40 (one point per question)

Score to pass the exam: 26 (or more)

Percentage of passing the exam: 65% (or more)

**Feedback on this sample exam as a whole (40 questions) or on individual questions was provided in the German-language BETA versions of SET A in the period June - August 2023 by:** Armin Born (STB), Bettina Buth (HS-Anhalt), Klaus Erlenbach (imbus AG), Sabine Gschwandtner (imbus), Michaela Huhn (HS Ostfalia), Jörn Münzel (former GTB), Paul Müller (SQL/ATB), Reto Müller (STB), Arnd Pehl (imbus AG), Horst Pohlmann (GTB/TH-OWL), Stephan Weissleder (GTB), Marc-Florian Wendland (GTB), Volkmar Richter (HS Anhalt), Ralf Reissing (GTB/Hochschule Coburg).

The preparation of the English version was supported by Ecaterina Irina Manole, Debra Friedenbergl, and Horst Pohlmann.

Note: Compared to the original English version, considerable adaptations have been made; some questions have also been replaced.

Question 1	FL-1.1.1	K1	Score 1.0
------------	----------	----	-----------

**Which of the following statements describes an achievable test objective?**

**Please choose ONE option! (1 out of 4)**

a)	To prove that there are no unfixed defects in the system under test	<input type="checkbox"/>
b)	To prove that there will be no failures after the implementation of the system into production	<input type="checkbox"/>
c)	To reduce the risk level of the test object and to build confidence in the quality level	<input checked="" type="checkbox"/>
d)	To verify that there are no untested combinations of inputs	<input type="checkbox"/>

FL-1.1.1 (K1) Identify typical test objectives

Justification:

- a) FALSE – It is impossible to prove that there are no remaining defects in the system under test. (see testing principle 1, see section 1.3, principles of testing)
- b) FALSE – (see testing principle 1, see section 1.3, principles of testing)
- c) **CORRECT – Testing finds defects and failures which reduces the level of risk and at the same time gives more confidence in the quality level of the test object (see section 1.1.1; 4<sup>th</sup> + 8<sup>th</sup> bullet point).**
- d) FALSE – It is impossible to test all combinations of inputs (see testing principle 2, see section 1.3, principles of testing)

Question 2	FL-1.1.2	K2	Score 1.0
------------	----------	----	-----------

**What is the main difference between testing and debugging?**

**Please choose ONE option! (1 out of 4)**

a)	Testing is the process of finding defects, while debugging is the process of fixing defects.	<input checked="" type="checkbox"/>
b)	Testing verifies requirements, while debugging verifies design.	<input type="checkbox"/>
c)	Testing is the process of running software, while debugging is the process of analyzing the software.	<input type="checkbox"/>
d)	Testing is the process of defect prevention, while debugging is the process of defect elimination.	<input type="checkbox"/>

FL-1.1.2 (K2) Differentiate testing from debugging

Justification: (cf. ISTQB® Foundation Level Syllabus V.4.0; Section 1.1.2)

- a) **CORRECT** – Debugging is the process of finding, analyzing, and eliminating the causes of failures in a component or system after, among other things, dynamic testing for the purpose of debugging (see Syllabus V.4.0, Section 1.1.2).
- b) FALSE – Testing and debugging are not limited to requirements review and design.
- c) FALSE – Testing and debugging involve both the execution and analysis of software.
- d) FALSE – Testing and debugging both aim to prevent and eliminate defects.

Question 3	FL-1.3.1	K2	Score 1.0
------------	----------	----	-----------

You are part of a team testing a new system. You've noticed that no changes have been made to the existing regression test cases for several iterations, and no new bugs have been uncovered by regression testing. Your manager is satisfied, but you are not.

Which testing principle best explains your skepticism?

Please choose ONE option! (1 out of 4)

a)	Old tests become less effective	<input checked="" type="checkbox"/>
b)	Absence-of-errors fallacy	<input type="checkbox"/>
c)	Defects cluster together	<input type="checkbox"/>
d)	Exhaustive testing is impossible	<input type="checkbox"/>

FL-1.3.1 (K2) Explain the seven testing principles

Justification:

- a) **CORRECT** – This principle means that if the same tests are repeated over and over again, eventually these tests no longer find any new defects. This is probably why the tests all passed in this release as well (cf. Syllabus 4.0, section 1.3, point 5 “Tests wear out”).
- b) **FALSE** – This principle says about the mistaken belief that just finding and fixing a large number of defects will ensure the success of a system (cf. Syllabus 4.0, section 1.3, point 7)
- c) **FALSE** – This principle says that a small number of components usually contain most of the defects (cf. Syllabus 4.0, section 1.3, point 4)
- d) **FALSE** – This principle states that testing all combinations of inputs and preconditions is not feasible (cf. Syllabus 4.0, section 1.3, point 2).

Question 4	FL-1.4.1	K2	Score	1.0
------------	----------	----	-------	-----

**You work in a team that develops a mobile application for ordering food. In the current iteration the team decides to implement the payment functionality.**

**Which of the following activities is a part of test analysis?**

**Please choose ONE option! (1 out of 4)**

a)	Perform the effort estimation for testing the integration of the mobile application with the payment service.	<input type="checkbox"/>
b)	Decide whether to test the ability to split payments among multiple users.	<input checked="" type="checkbox"/>
c)	Using boundary value analysis (BVA) to derive the test data for the test cases that check the correct payment processing for the minimum allowed amount to be paid.	<input type="checkbox"/>
d)	Analysis of the deviation between the actual and the expected result after the execution of a test case.	<input type="checkbox"/>

FL-1.4.1 (K2) Summarize the different test activities and tasks

Justification:

- a) FALSE – Estimating the test effort is part of test planning (cf. syllabus V.4.0; section 5.1.4)
- b) CORRECT – This is an example of the definition of test conditions, which is a part of test analysis. (cf. syllabus V.4.0; section 1.4.1, part test analysis).**
- c) FALSE – The use of test techniques (e. g., boundary value analysis (BVA) to derive test data is part of test design (cf. Syllabus V.4.0; Section 1.4.1, Test design part) or test means (e. g., test data) required for test realization (cf. Syllabus V.4.0; Section 1.4.1, part Test Realization).
- d) FALSE – The analysis between the actual and the expected result after the execution of a test case is part of the test execution. (cf. syllabus V.4.0; section 1.4.1, part test execution).



Question 5	FL-1.4.4	K2	Score	1.0
------------	----------	----	-------	-----

Which of the following statements **BEST** describes how value is added by establishing and maintaining traceability between the test base and the test ware?

Please choose **ONE** option! (1 out of 4)

a)	Maintenance testing can be fully automated on the basis of changes to the original requirements.	<input type="checkbox"/>
b)	Whether or not the targeted coverage has been achieved can be more efficiently determined.	<input checked="" type="checkbox"/>
c)	The test management role can determine which testers found the defects with the highest severity.	<input type="checkbox"/>
d)	Code areas that may be affected by side effects of a change can be targeted through regression testing.	<input type="checkbox"/>

FL-1.4.4 (K2) Explain the value of maintaining traceability

Justification:

- a) FALSE – Traceability allows requirements to be linked to test cases (see CTFL Syllabus 4.0, Section 1.4.4, 3<sup>rd</sup> paragraph), but it does not help automate test cases.
- b) **CORRECT** – If test cases are linked to requirements, the addition of a new test case (with traceability) can determine whether previously uncovered requirements or parts of requirements are covered by the new test case (see CTFL Syllabus 4.0, Section 1.4.4, 1<sup>st</sup> bullet).
- c) FALSE – The traceability between test base and test ware does not provide information about which testers have identified the high severity defects. One could determine this through evaluations in the defect management tool if necessary, but in terms of the syllabus, it is never about evaluating individuals.
- d) FALSE – Traceability from test base to test ware allows analysis between requirements and associated test cases for test coverage. Therefore, derivations can be determined when a requirement change is made to the associated test cases (see CTFL Syllabus 4.0, Section 1.4.4, 1<sup>st</sup> bullet point). Areas (in the code) that are affected by a change and for which side effects could be determined cannot be determined with this traceability.

Question 6	FL-1.4.5	K2	Score 1.0
------------	----------	----	-----------

**Which of the following statements BEST compares the different roles in testing?**

**Please choose ONE option! (1 out of 4)**

a)	The testing role executes test cases, the test management role plans and monitors the testing activities and reports the deviation to all testers.	<input type="checkbox"/>
b)	The testing role performs test analysis and test design activities, creates and executes test cases, and the test management role coordinates testing resources and reports to stakeholders.	<input checked="" type="checkbox"/>
c)	The testing role decides the tests to be automated and prioritizes test cases, and the test management role analyzes risks and prioritizes tests.	<input type="checkbox"/>
d)	The testing role performs static and dynamic component testing, and the test management role performs system testing and acceptance testing.	<input type="checkbox"/>

FL-1.4.5 (K2) Compare the different roles in testing.

Justification: (cf. ISTQB® Foundation Level Syllabus V.4.0; Section 1.4.5)

- a) FALSE – Reporting deviations is assigned to the testing role and not to the test management role. (See also CTFL Syllabus V.4.0; Section 1.4.5; 3<sup>rd</sup> paragraph; last sentence: "The testing role focuses primarily on the activities of test analysis, test design, test implementation, and test execution." Test execution "(...) reporting of the deviation based on the observed failure effects (see Section 5.5)).
- b) CORRECT – because it describes the main tasks of each role in testing in a meaningful way. The testing role executes test cases, creates and designs test cases, performs test analysis and design activities, and reports defects; the Test Management role coordinates test resources and reports to stakeholders. (See CTFL Syllabus V.4.0; Section 1.4.5, 2<sup>nd</sup> + 3<sup>rd</sup> par.).**
- c) FALSE – because it confuses the roles of testing. The role of testing does not solely prioritize test cases and does not alone decide which tests to automate.
- d) FALSE – because it oversimplifies the types of tests that each role can perform. The testing role is not limited to component testing. The test management role monitors the tests, it does not execute the test. Further, there is no restriction on specific levels of testing.

Question 7	FL-1.5.3	K2	Score 1.0
------------	----------	----	-----------

**Which of the following BEST explains a benefit of independence of testing?**

**Please choose ONE option! (1 out of 4)**

a)	The use of an independent test team allows project management to assign responsibility for the quality of the final deliverable to the test team.	<input type="checkbox"/>
b)	If a test team external to the organization can be afforded, then there are distinct benefits in terms of this external team not being so easily swayed by the delivery concerns of project management and the need to meet strict delivery deadlines.	<input type="checkbox"/>
c)	An independent test team can work separately from the developers, need not be distracted with project requirement changes, and can restrict communication with the developers to defect reporting through the defect management system.	<input type="checkbox"/>
d)	When specifications contain ambiguities and inconsistencies, assumptions are made by developers on their interpretation, and an independent test team can be useful in questioning those assumptions and the interpretation made by the developer.	<input checked="" type="checkbox"/>

FL-1.5.3 (K2) Distinguish the benefits and drawbacks of independence of testing

Justification:

- a) FALSE – Quality should be the responsibility of everyone working on the project and not the sole responsibility of the test team
- b) FALSE – First, it is not a benefit if an external test team does not meet delivery deadlines, and second, there is no reason to believe that external test teams will feel they do not have to meet strict delivery deadlines
- c) FALSE – It is bad practice for the test team to work in complete isolation, and we would expect an external test team to be concerned with changing project requirements and communicating well with developers
- d) **CORRECT** – Specifications are never perfect, meaning that assumptions will have to be made by the developer. An independent tester is useful in that they can challenge and verify the assumptions and subsequent interpretation made by the developer (cf. CTFL Syllabus, section 1.5.3, 3. Par., last sentence).

<b>Question 8</b>	<b>FL-1.5.2</b>	<b>K1</b>	<b>Score 1.0</b>
-------------------	-----------------	-----------	------------------

**How is the whole team approach present in the interactions between testers and business representatives?**

**Please choose ONE option! (1 out of 4)**

a)	Business representatives decide together with project management on test automation approaches	<input type="checkbox"/>
b)	Testers help business representatives to define test strategy	<input type="checkbox"/>
c)	Business representatives are not part of the whole team approach	<input type="checkbox"/>
d)	Testers help business representatives to create suitable acceptance tests	<input checked="" type="checkbox"/>

FL-1.5.2 (K1) Recall the advantages of the whole team approach

Justification:

- a) FALSE – The test automation approach is defined by testers with the help of developers and business representatives (See Syllabus V.4.0; Section 1.5.2; Paragraph 3).
- b) FALSE – The test strategy is decided in collaboration with the developers (See Syllabus V.4.0; Section 1.5.2; Paragraph 3).
- c) FALSE – Testers, developers, and business representatives are part of the whole team approach (See Syllabus V.4.0; Section 1.5.2; Paragraph 3).
- d) **CORRECT** – Testers will work closely with business representatives to ensure that the desired quality levels are achieved. This includes supporting and collaborating with them to help them create suitable acceptance tests (See Syllabus V.4.0; Section 1.5.2; Paragraph 3).

<b>Question 9</b>	<b>FL-2.1.2</b>	<b>K2</b>	<b>Score 1.0</b>
-------------------	-----------------	-----------	------------------

**Which of the following statements BEST describes a good practice for testing that applies to all software development lifecycles?**

**Please choose ONE option! (1 out of 4)**

a)	Testing should be performed only after development is complete.	<input type="checkbox"/>
b)	Testing should be performed under the leadership of development.	<input type="checkbox"/>
c)	Testing should start early in the development process.	<input checked="" type="checkbox"/>
d)	Testing should be performed in a development test environment.	<input type="checkbox"/>

FL-2.1.2 (K2) Identify good practices for testing that apply to all software development life cycles.

Justification:

- a) FALSE – Testing should NOT be done after development is complete, as this can lead to late discovery of bugs and increase the cost of fixing bugs. (cf. CTFL Syllabus 4.0, Section 2.1.2, 3<sup>rd</sup> bullet point).
- b) FALSE – Testing should not be led by development because developers may not be able to identify their own bugs. (CTFL Syllabus 4.0, section 2.1.2, clauses 1.4.5, 2<sup>nd</sup> paragraph, last sentence).
- c) CORRECT – Testing should begin early in the development process to detect defects as early as possible and minimize the cost of fixing defects. (See also: CTFL Syllabus 4.0, Section 2.1.2., 3. bullet point and Section 1.3).**
- d) FALSE – Testing should not be performed in a development test environment as this may not identify all problems that may occur on other environments. Testing should be performed in a representative test environment. (See CTFL Syllabus 4.0, Section 2.1.5, last bullet point).

Question 10	FL-2.1.3	K1	Score 1.0
-------------	----------	----	-----------

**Which of the following statements BEST describes the acceptance test-driven development (ATDD) approach?**

**Please choose ONE option! (1 out of 4)**

a)	In ATDD, acceptance criteria are typically created based on the given/when/then format.	<input type="checkbox"/>
b)	In ATDD, test cases are developed first and then the software is implemented incrementally against the test cases and defined acceptance criteria.	<input type="checkbox"/>
c)	In ATDD, tests are derived from acceptance criteria as part of the system design.	<input checked="" type="checkbox"/>
d)	With ATDD, tests are based on the desired behavior of the software, which makes it easier for team members to understand the tests and the defined acceptance criteria.	<input type="checkbox"/>

FL-2.1.3 (K1) Recall the examples of test-first approaches to development

Justification:

- a) FALSE – This format is more often used in behavior-driven development (BDD) (See CTFL Syllabus V.4.0; Section 2.1.3, 3<sup>rd</sup> listed approach).
- b) FALSE – It is the description of test-driven development (TDD) (See CTFL Syllabus V.4.0; Section 2.1.3, 1<sup>st</sup> listed approach).
- c) **CORRECT – In acceptance test-driven development (ATDD) tests are written from acceptance criteria as part of the business requirements (See CTFL Syllabus V.4.0; Section 2.1.3, 3<sup>rd</sup> listed approach, 1. Bullet point).**
- d) FALSE – The desired behavior is used in behavior-driven development(BDD). (See CTFL Syllabus V.4.0; Section 2.1.3, 3<sup>rd</sup> listed approach).

Question 11	FL-2.1.5	K2	Score 1.0
-------------	----------	----	-----------

**Which of the following is NOT an example of the shift left approach?**

**Please choose ONE option! (1 out of 4)**

a)	Reviewing the user requirements before they are formally accepted by the stakeholders	<input type="checkbox"/>
b)	Create component test cases before programming the associated code	<input type="checkbox"/>
c)	Executing a performance efficiency test for a component during component testing	<input type="checkbox"/>
d)	Execution of non-functional tests, starting during system level testing	<input checked="" type="checkbox"/>

FL-2.1.5 (K2) Explain the shift-left approach

Justification:

- a) FALSE – Early review is an example of the shift left approach (CTFL Syllabus V.4.0; Section 2.1.5, 1<sup>st</sup> bullet point, mutatis mutandis).
- b) FALSE – TDD is an example of the shift left approach (CTFL Syllabus V.4.0; Section 2.1.5, 2<sup>nd</sup> bullet point).
- c) FALSE – Early non-functional testing is an example of the shift left approach (CTFL Syllabus V.4.0; Section 2.1.5, 5<sup>th</sup> bullet point).
- d) **CORRECT – Early non-functional testing is an example of the shift-left approach, but NOT until the system test level is NOT an example of the shift-left approach. (CTFL Syllabus V.4.0; Section 2.1.5, 5<sup>th</sup> bullet point)**

Question 12	FL-2.1.6	K2	Score 1.0
-------------	----------	----	-----------

**Which of the arguments below would you use to convince your manager to organize retrospectives at the end of each release cycle?**

**Please choose ONE option! (1 out of 4)**

a)	Retrospectives are very popular these days and clients would appreciate it if we added them to our processes.	<input type="checkbox"/>
b)	Performing regular retrospectives will save the organization money because end user representatives do not provide immediate feedback about the product.	<input type="checkbox"/>
c)	Process weaknesses identified during the retrospective can be analyzed and serve as a to do list for the organization's continuous process improvement program.	<input checked="" type="checkbox"/>
d)	Retrospectives embrace the five values including courage and respect, which are crucial to maintain continuous improvement in the organization.	<input type="checkbox"/>

FL-2.1.6 (K2) Explain how retrospectives can be used as a mechanism for process improvement

Justification:

- a) FALSE – Retrospectives are more useful for identifying improvement opportunities and have little importance for clients
- b) FALSE – Business representatives are not giving feedback about the product itself. Therefore, there is no financial gain to the organization.
- c) CORRECT – Regularly conducted retrospectives, when appropriate follow up activities occur, are critical to continual improvement of development and testing (cf. ISTQB® Foundation Level Syllabus V.4.0; Section 2.1.6, 2<sup>nd</sup> paragraph, 2<sup>nd</sup> sentence.)**
- d) FALSE – The option focuses on the social aspects of a retrospective, which are important but do not reflect the main goals of the retrospective.



Question 13	FL-2.2.1	K2	Score 1.0
-------------	----------	----	-----------

**Which types of defects (1-4) fit which test levels (A-D) BEST?**

- 1. Defects in system behavior as it deviates from the user's business needs**
  - 2. Defects in communication between components**
  - 3. Defects in an isolated component**
  - 4. Defects in an incorrectly implemented user story.**
- 
- A. Component testing**
  - B. Component Integration testing**
  - C. System testing**
  - D. Acceptance testing**

**Please choose ONE option! (1 out of 4)**

a)	1D, 2B, 3A, 4C	<input checked="" type="checkbox"/>
b)	1D, 2B, 3C, 4A	<input type="checkbox"/>
c)	1B, 2A, 3D, 4C	<input type="checkbox"/>
d)	1C, 2A, 3B, 4D	<input type="checkbox"/>

FL-2.2.1 (K2) Distinguish the different test levels

Justification:

The test basis for acceptance testing is the user's business needs (1D). (see CTFL Syllabus 4.0, Bulletpoint Acceptance Test, 1<sup>st</sup> sentence).

The communication between the components is tested during the component integration test of the components (2B). (see CTFL Syllabus 4.0, bullet point component integration test, 1<sup>st</sup> sentence).

Defects in an isolated component can be detected in the Component Test (3A) because this test checks the internal structure and functionality of a single component. (See CTFL Syllabus 4.0, Bullet Component Test, 1<sup>st</sup> sentence).

Business rules are the test basis for system testing (4C).

**Hence a) is CORRECT.**

Question 14	FL-2.3.1	K2	Score 1.0
-------------	----------	----	-----------

**Your organization’s test strategy suggests that once a system is planned for retirement, data migration to a new system shall be tested.**

**As part of what test activity is this testing MOST likely to be performed?**

**Please choose ONE option! (1 out of 4)**

a)	Maintenance testing	<input checked="" type="checkbox"/>
b)	Regression testing	<input type="checkbox"/>
c)	Component testing	<input type="checkbox"/>
d)	Component integration testing	<input type="checkbox"/>

FL-2.3.1 (K2) Summarize maintenance testing and its triggers

Justification:

- a) **CORRECT** – When a system is retired, this can require testing of data migration, which is a form of maintenance testing. This is a type of test performed when a system is retired or modified to ensure that functionality and performance are maintained. The need to migrate data falls under migration. Changing to a successor system falls under system replacement, both of which are triggers for maintenance testing). (Syllabus V.4.0; Section 2.3, bullets 2 and 3).
- b) **FALSE** – Regression testing verifies whether a fix accidentally affected the behavior of other parts of the code, but now we are talking about data migration to a new system
- c) **FALSE** – Component testing focuses on individual hardware or software components, not on data migration
- d) **FALSE** – Component integration testing focuses on interactions between components and/or systems, not on data migration

Question 15	FL-3.1.2	K2	Score	1.0
-------------	----------	----	-------	-----

**Which of the following is NOT a benefit of static testing?**

**Please choose ONE option! (1 out of 4)**

a)	Evaluating and remediating anomalies discovered through static analysis can take a significant amount of time and resources	<input checked="" type="checkbox"/>
b)	Fixing defects found during static testing is generally much less expensive than fixing defects found during dynamic testing	<input type="checkbox"/>
c)	Finding coding defects that might not have been found by only performing dynamic testing	<input type="checkbox"/>
d)	Detecting gaps and inconsistencies in requirements	<input type="checkbox"/>

FL-3.1.2 (K2) Explain the value of static testing

Justification:

- a) **CORRECT** – The (manual) evaluation and resolution of anomalies uncovered by static analysis can require significant time and resources." This is a potential disadvantage of static testing, especially when the test object is very complex and large. (cf. CTFL Syllabus V.4.0; Section 3.1.2, last paragraph).
- b) **FALSE** – This is a clear advantage of static testing, as it improves the quality of the test object and reduces troubleshooting and maintenance costs. (cf. CTFL Syllabus V.4.0; Section 3.1.2, 1<sup>st</sup> paragraph).
- c) **FALSE** – This is an advantage of static testing. Static testing does not execute, but finds errors in the code that may not be reached in dynamic testing. (cf. CTFL Syllabus V.4.0; Section 3.1.2, 1<sup>st</sup> paragraph).
- d) **FALSE** – This is an advantage of static testing. This is because static testing can help increase requirements quality and reduce the risk of misinterpretation or misunderstanding. (cf. CTFL Syllabus V.4.0; Section 3.1.2, 2<sup>nd</sup> paragraph, Section 3.1.3, 1<sup>st</sup> paragraph).

Question 16	FL-3.2.1	K1	Score 1.0
-------------	----------	----	-----------

**Which of the following is a benefit of early and frequent feedback by stakeholders?**

**Please choose ONE option! (1 out of 4)**

a)	It improves the test process for future projects	<input type="checkbox"/>
b)	It forces customers to prioritize their requirements based on agreed risks	<input type="checkbox"/>
c)	It is the only way to measure the quality of changes	<input type="checkbox"/>
d)	It helps avoid requirements misunderstandings	<input checked="" type="checkbox"/>

FL-3.2.1 (K1) Identify the benefits of early and frequent stakeholder feedback

Justification:

- a) FALSE – Feedback can improve the test process, but if one only wants to improve future projects, the feedback does not need to come early or frequently
- b) FALSE – Feedback is not used to prioritize requirements
- c) FALSE – The quality of changes can be measured in multiple ways
- d) **CORRECT** – Early and frequent feedback enables potential quality problems, such as misunderstood requirements, to be identified at an early stage. (see ISTQB® Foundation Level Syllabus V.4.0; Section 3.2.1, 1<sup>st</sup> paragraph).

Question 17	FL-3.2.4	K2	Score 1.0
-------------	----------	----	-----------

**Your organization's reviews have the following characteristics:**

- The main purpose is to communicate or train reviewers.
- The meeting is led by the author of the work product.
- There is individual independently preparation of the reviewer before the meeting.
- A review report is produced.

**Which of the following review types is MOST likely being used?**

**Please choose ONE option! (1 out of 4)**

a)	Informal review	<input type="checkbox"/>
b)	Walkthrough	<input checked="" type="checkbox"/>
c)	Technical review	<input type="checkbox"/>
d)	Inspection	<input type="checkbox"/>

FL-3.2.4 (K2) Compare and contrast the different review types

Justification:

Considering the attributes:

- The primary purpose is to communicate and educate reviewers as an important goal of a walkthrough (see CTFL Syllabus V.4.0; Section 3.2.4, Types of Reviews).
- The review meeting is led by the author of the work product – this is not allowed for inspections and is typically not done in technical reviews. A moderator is needed in walkthroughs and is allowed for informal reviews (See CTFL Syllabus V.4.0; Section 3.2.4, Types of Reviews).
- Individual reviewers find potential anomalies during preparation – all types of reviews can include individual reviewers (even informal reviews) (See CTFL Syllabus V.4.0; Section 3.2.4, Types of Reviews).
- A review report is produced – all types of reviews can produce a review report, although informal reviews do not require documentation (See CTFL Syllabus V.4.0; Section 3.2.4, Types of Reviews).

Hence b) is CORRECT.

Question 18	FL-3.2.5	K1	Score 1.0
-------------	----------	----	-----------

**Which of these statements is NOT a factor that contributes to successful reviews?**

**Please choose ONE option! (1 out of 4)**

a)	Participants should dedicate adequate time for the review.	<input type="checkbox"/>
b)	Splitting large work products into small parts is recommended so that reviewers (reviewers) do not lose focus.	<input type="checkbox"/>
c)	Establishing clear objectives and measurable exit criteria for the review.	<input type="checkbox"/>
d)	Management's personal involvement in communicating findings.	<input checked="" type="checkbox"/>

FL-3.2.5 (K1) Recall the factors that contribute to a successful review

Justification:

- a) FALSE – Adequate time for individuals is a success factor (Syllabus V.4.0; Section 3.2.5, 5<sup>th</sup> bullet point).
- b) FALSE – Splitting work products into small adequate parts is a success factor (CTFL Syllabus V.4.0; Section 3.2.5, 3<sup>rd</sup> bullet point).
- c) FALSE – Establishing clear objectives and measurable exit criteria for the review is a success factor according to the syllabus and in practice. (CTFL Syllabus V.4.0; Section 3.2.5, 1<sup>st</sup> bullet point).
- d) **CORRECT** – Management is responsible for the budget and for supporting the review process, but should not be personally involved in communicating the findings. (CTFL Syllabus V.4.0; Section 3.2.5, 6<sup>th</sup> bullet point and Section 3.2.3, 1<sup>st</sup> bullet point of bullet point list).

Question 19	FL-4.1.1	K2	Score	1.0
-------------	----------	----	-------	-----

**Which of the following is a characteristic of experience-based test techniques?**

**Please choose ONE option! (1 out of 4)**

a)	Test cases are created based on detailed design information	<input type="checkbox"/>
b)	The number of interfaces tested is used to measure the coverage	<input type="checkbox"/>
c)	The techniques heavily rely on the tester's knowledge of the software and the business domain	<input checked="" type="checkbox"/>
d)	The test cases are used to identify deviations from the requirements	<input type="checkbox"/>

FL-4.1.1 (K2) Distinguish black-box, white-box and experience-based test techniques

Justification:

- a) FALSE – This is a common characteristic of white-box test techniques. Test conditions, test cases and test data are derived from a test base that may include code, software architecture, detailed design or any other source of information regarding the structure of the software.
- b) FALSE – This is a common characteristic of white-box test techniques. The degree of coverage is measured based on the tested interfaces.
- c) **CORRECT** – This is a common feature of experience-based testing methods. This knowledge and experience, including the expected use of the software, its environment, the likely defects and the distribution of these defects, is used to define tests. (cf. ISTQB® Foundation Level Syllabus V.4.0; Section 4.1).
- d) FALSE – This is a common characteristic of black-box test techniques. Test cases may be used to detect gaps in the requirements and the implementation of the requirements, as well as deviations from the requirements.



Question 20	FL-4.2.1	K3	Score 1.0
-------------	----------	----	-----------

You are testing the software for a self-service American gas pump. After lifting the nozzle and selecting the desired grade of fuel, the customer enters the desired amount of fuel in gallons using a keypad. The keypad allows only numeric entry. Between 0.1 and 50.0 gallons can be dispensed per fill-up.

Which of the following answers represents a minimum set of input values that covers all valid and invalid fuel quantity equivalence partitions?

Please choose ONE option! (1 out of 4)

a)	0.0; 20.0; 60.0	<input checked="" type="checkbox"/>
b)	0.0; 0.1; 50.0	<input type="checkbox"/>
c)	0.0; 0.1; 50.0; 70.0	<input type="checkbox"/>
d)	-0.1; 0.0; 0.1; 49.9; 50.0; 50.1	<input type="checkbox"/>

FL-4.2.1 (K3) Apply equivalence class partitioning to derive test cases.

Justification: (see ISTQB® Certified Tester Syllabus Foundation Level 4.0)

There are three equivalence classes for this input parameter (see CTFL Syllabus 4.0, Section 4.2.1):

- No quantity is entered and therefore no sale is completed (0.0 gallons) - Invalid class.
- A valid quantity is entered and the sale occurs (0.1 to 50.0 gallons) - valid class
- An invalid quantity is entered and therefore no sale is completed (>50.0 gallons) - invalid class

For this:

- a) **CORRECT** – This list of input values defines exactly one test case per equivalency class (see CTFL Syllabus 4.0, Section 4.2.1, 5<sup>th</sup> paragraph).
- b) FALSE – This list of input values does not cover invalidly exceeding the 50.0 gallon maximum allowed (see CTFL Syllabus 4.0, Section 4.2.1, 5<sup>th</sup> paragraph).
- c) FALSE – This set of input values represents two tests for the valid equivalence class, which is not the minimum of one test (see CTFL Syllabus 4.0, Section 4.2.1, 5<sup>th</sup> paragraph).
- d) FALSE – This set of input values covers three boundary values each for the two boundaries values 0.1 and 50.0, not the minimum number required to cover the equivalence classes (see CTFL Syllabus 4.0, Section 4.2.1, 5<sup>th</sup> paragraph).

Question 21	FL-4.2.2	K3	Score 1.0
-------------	----------	----	-----------

You are testing an e-commerce system that sells bulk food items such as spices, flour, and sugar. The units in which the items are sold are either grams or kilograms. Regardless of the units, the smallest valid order quantity is 0.5 units (e. g., half a gram of cardamom pods) and the largest valid order quantity is 25.0 units (e. g., 25 kilograms of sugar). The accuracy of the order quantity is 0.1 units.

Which of the following input values cover only the limits with 2-value limit analysis for the order quantity?

Please choose ONE option! (1 out of 4)

a)	0.3; 24.9; 25.2	<input type="checkbox"/>
b)	0.4; 0.5; 0.6; 24.9;25.0; 25.1	<input type="checkbox"/>
c)	0.4; 0.5; 25.0; 25.1	<input checked="" type="checkbox"/>
d)	0.5; 0.6; 24.9; 25.0	<input type="checkbox"/>

FL-4.2.2 (K3) Apply boundary value analysis to derive test cases.

Justification: (cf. ISTQB® Syllabus Foundation Level 4.0).

There are three equivalence classes whose boundaries are shown as follows:

- Invalid to low (0.4 and below)
- Valid (0.5 to 25.0)
- Invalid too high (25.1 and higher)

The 2-value boundary value analysis (see CTFL Syllabus 4.0, Section 4.2.2, 4<sup>th</sup> paragraph) defines two cover elements for each limit value of an ordered class, the boundary value and its closest neighbor belonging to the adjacent class. So here 0.5 (limit value) and 0.4 (adjacent class) and 25.0 and 25.1.

Therefore:

- a) FALSE – These values cover the individual equivalence classes, but not their boundary values (see CTFL Syllabus 4.0, Sections 4.2.1 and 4.2.2).
- b) FALSE – These input values would be correct if the 3-value method were used. The four boundaries of the 2-value method (see answer c) are included in this set of input values, but the 2-value method was explicitly asked for. (See CTFL 4.0, section 4.2.2, 5<sup>th</sup> paragraph).
- c) CORRECT – This set of input values covers the four boundaries selected by using the 2-value method (see CTFL Syllabus 4.0, Section 4.2.2, 4<sup>th</sup> paragraph).**
- d) FALSE – These four values are all included in the valid equivalence class, the boundary values from the two invalid equivalence classes are missing (see CTFL Syllabus 4.0, Section 4.2.2, 4<sup>th</sup> paragraph).

Question 22	FL-4.2.3	K3	Score 1.0
-------------	----------	----	-----------

Newly hired employees of a company can agree on individual goals with their superiors, the achievement of which is linked to their bonus. However, this bonus is only paid to them if they have been employed by the company for more than one year.

This situation can be illustrated in a decision table:

Test Case-ID		T1	T2	T3	T4	T5
Condition1	Employment longer than one year?	YES	NO	NO	YES	NO
Condition2	Target agreed?	NO	NO	YES	YES	YES
Condition3	Target achieved?	NO	NO	YES	YES	NO
Action	Payment of the bonus?	NO	NO	NO	YES	NO

Which of the following test cases describes a real-world situation that is missing from the above decision table?

Please choose ONE option! (1 out of 4)

a)	Condition1 = YES, Condition2 = NO, Condition3 = YES, Action = NO	<input type="checkbox"/>
b)	Condition1 = YES, Condition2 = YES, Condition3 = NO, Action = YES	<input type="checkbox"/>
c)	Condition1 = NO, Condition2 = NO, Condition3 = YES, Action = NO	<input type="checkbox"/>
d)	Condition1 = YES, Condition2 = YES, Condition3 = NO, Action = NO	<input checked="" type="checkbox"/>

FL-4.2.3 (K3) Apply decision table testing to derive test cases.

Justification: (see ISTQB® Certified Tester Syllabus Foundation Level 4.0)

- a) FALSE – The combination of conditions is an infeasible combination, because if no goal has been agreed, then the goal that has not been agreed cannot be achieved. Therefore, it is not a valid scenario that occurs in practice. (See CTFL Syllabus 4.0, Section 4.2.3, Paragraph 4).
- b) FALSE – The combination of conditions is a valid, occurring situation, but the action is technically incorrect. Since the objective was not achieved, no award should be made. (See CTFL Syllabus 4.0, Section 4.2.3, 2<sup>nd</sup> paragraph).
- c) FALSE – The combination of conditions is an infeasible combination because if no objective was agreed, then the unagreed objective cannot be achieved. Therefore, it is not a valid scenario that occurs in practice. (See CTFL Syllabus 4.0, Section 4.2.3, 4<sup>th</sup> paragraph) (see answer a)).
- d) **CORRECT** – The test case describes the technically correct situation (counterpart to answer b) that failure to achieve the agreed target results in non-payment of the bonus if the employee is employed for more than one year. This situation may occur in practice, but is not included in the decision table. (See CTFL Syllabus 4.0, Section 4.2.3, 2<sup>nd</sup> paragraph).

Question 23	FL-4.2.4	K3	Score 1.0
-------------	----------	----	-----------

Which of the following statements about the state transition diagram and test case table below is TRUE?

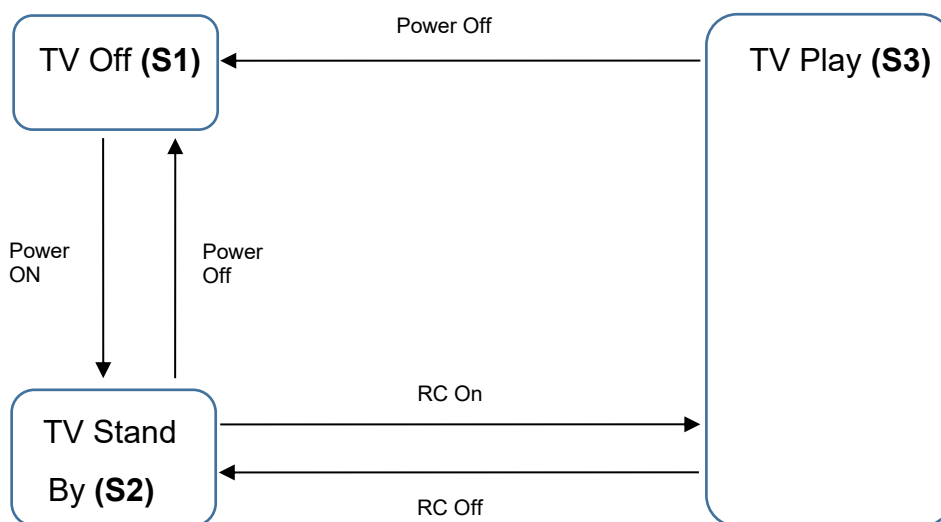

Test case	1	2	3	4	5
Initial state	S1	S2	S2	S3	S3
Input	Power On	Power Off	RC On	RC Off	Power Off
Final state	S2	S1	S3	S2	S1

Please choose ONE option! (1 out of 4)

a)	The test cases execute all transitions in the state transition diagram, achieving 100% coverage of all transitions.	<input type="checkbox"/>
b)	The test cases execute all valid transitions in the state transition diagram. This achieves 100% 0-switch coverage.	<input checked="" type="checkbox"/>
c)	The test cases execute only some of the valid transitions in the state transition diagram. Therefore, the 0-switch coverage is less than 100%.	<input type="checkbox"/>
d)	Test Case 2 is not required for 100% 0-switch coverage, since state S1 is already covered by Test Case 5.	<input type="checkbox"/>

FL-4.2.4 (K3) Apply state transition testing to derive test cases from given requirements.

Justification: (see CTFL CORE Syllabus 4.0).

The proposed test cases cover exactly all five possible valid transitions in the given state transition diagram (S1-> S2, S2-> S1, S2-> S3, S3-> S2, S3-> S1).

Therefore:

- a) FALSE – because no invalid transitions, such as S1->S3, are executed.
- b) CORRECT – because all 5 valid transitions are performed.**
- c) FALSE – because all valid transitions are executed (see b).
- d) FALSE – because the 0-switch overlap is not a matter of overlapping states, but of overlapping transitions.



Question 24	FL-4.3.1	K2	Score	1.0
-------------	----------	----	-------	-----

**Which of the following describes statement coverage?**

**Please choose ONE option! (1 out of 4)**

a)	It is a metric for calculating and measuring the percentage of test cases executed.	<input type="checkbox"/>
b)	It is a metric that indicates the percentage of statements in the code that have already been executed by test cases.	<input checked="" type="checkbox"/>
c)	It is a metric for measuring the number of statements in the code executed by test cases that did not reveal a failure.	<input type="checkbox"/>
d)	It is a metric that provides true/false confirmation that all statements are covered by executed test cases.	<input type="checkbox"/>

FL-4.3.1 (K2) Explain statement testing

Justification: (cf. ISTQB® Certified Tester Syllabus Foundation Level 4.0)

- a) FALSE – Statement coverage measures the percentage of statements executed (covered) by test cases and is not related to the number of test cases executed (see CTFL syllabus 4.0, section 4.3.1, paragraph 1).
- b) CORRECT – Statement testing aims to execute statements in code through test cases until acceptable statement coverage is achieved. Statement coverage is measured as the number of statements executed by test cases divided by the total number of executable statements in the test object, expressed as a percentage (see CTFL 4.0, Section 4.3.1, Paragraph 1).**
- c) FALSE – Statement coverage measures only executed instructions, regardless of whether or not any failures or defects were determined with them (see CTFL 4.0, Section 4.3.1, 1<sup>st</sup> and 2<sup>nd</sup> paragraphs).
- d) FALSE – Statement coverage is a metric that gives percentages and does not make a true/false statement (see CTFL Syllabus 4.0, Section 4.3.1, Paragraph 1). A true/false statement could be determined for the test objective of percent statement coverage, e. g., 100% statement coverage, but not for the statement coverage itself.

Question 25	FL-4.3.3	K2	Score 1.0
-------------	----------	----	-----------

**Which of the following statements is NOT true for white-box testing?**

**Please choose ONE option! (1 out of 4)**

a)	White-box testing is testing based on the analysis of the internal structure of a component or system.	<input type="checkbox"/>
b)	White-box coverage metrics can help identify additional tests to increase code coverage.	<input type="checkbox"/>
c)	White-box testing techniques can be used in addition to black-box testing techniques to increase confidence in the code.	<input type="checkbox"/>
d)	White-box testing can help identify unimplemented requirements.	<input checked="" type="checkbox"/>

FL-4.3.3 (K2) Explain the value of White-Box Testing

Justification

- a) FALSE – see glossary definition for white box testing.
- b) FALSE – White box coverage measurements provide an objective measure of coverage and provide the information necessary to create additional tests to increase coverage. (See Syllabus V.4.0; Section 4.3.3, 1<sup>st</sup> paragraph, 1<sup>st</sup> sentence).
- c) FALSE – White-box test techniques can be used in a complementary manner to black-box test techniques. In fact, this is recommended. (See Syllabus V.4.0; Section 4.3.3, 3<sup>rd</sup> paragraph).
- d) **CORRECT** – This is the weakness of the white-box test techniques. They are unable to identify the missing implementation because they are based only on the structure of the test object and not on the requirements specification. (cf. Syllabus V.4.0; Section 4.3.3, 1<sup>st</sup> paragraph, last sentence).

Question 26	FL-4.4.1	K2	Score	1.0
-------------	----------	----	-------	-----

Which of the following BEST describes the concept behind error guessing?

Please choose ONE option! (1 out of 4)

a)	Error guessing involves using your knowledge and experience of past defects and failures, and typical errors made by developers.	<input checked="" type="checkbox"/>
b)	Error guessing involves using your personal experience of development and the errors you previously made as a developer.	<input type="checkbox"/>
c)	Error guessing requires you to imagine that you are the user of the test object and to guess errors the user might make while interacting with it.	<input type="checkbox"/>
d)	Error guessing requires you, as a tester, to duplicate the development tasks so that defects and failures a developer might make can be identified.	<input type="checkbox"/>

Justification:

- a) CORRECT – The basic concept behind error guessing) is that the tester tries to guess what erroneous actions a developer might have taken and what defects might be present in the test object, based on past experience. This method is based on the assumption that defects are repetitive or similar. You can design your test cases to detect these potential defects. (CTFL Syllabus V.4.0; Section 4.4.1, 1<sup>st</sup> paragraph)
- b) FALSE – Although a tester who was formerly a developer can use his or her personal experience to identify test cases intuitively, the test technique is not based on prior development knowledge.
- c) FALSE – Error Guessing is not just a usability test technique to guess how users might interact incorrectly with the test object, but goes far beyond that (see option a).
- d) FALSE – Performing the development task yourself has several weaknesses that make it impractical, such as the fact that the tester would need to have the same skills as the developer, and the time required to perform the development yourself. It is not error guessing.

Question 27	FL-4.4.2	K2	Score 1.0
-------------	----------	----	-----------

The release of a brand-new application has been delayed and testing has started late, but you have very detailed domain knowledge and good analytical skills. The full requirements specification has not yet been shared with you, and management is asking for early test results.

What is the BEST test technique to use in this situation?

Please choose ONE option! (1 out of 4)

a)	Checklist-based testing	<input type="checkbox"/>
b)	Error guessing	<input type="checkbox"/>
c)	Exploratory testing	<input checked="" type="checkbox"/>
d)	Branch testing	<input type="checkbox"/>

FL-4.4.2 (K2) Explain exploratory testing

Justification:

- a) FALSE – This is a new product. You probably do not have a checklist for this product.
- b) FALSE – This is a new product. You probably don't have enough information to intuitively identify defects.
- c) **CORRECT** – Exploratory testing is most useful when few specifications are available and/or the testing schedule is tight. (CTFL Syllabus V.4.0; Section 4.4.2, 3<sup>rd</sup> paragraph, 1<sup>st</sup> sentence).
- d) FALSE – Statement testing is time-consuming, and your management is now asking for initial test results.

Question 28	FL-4.5.2	K2	Score	1.0
-------------	----------	----	-------	-----

**Which of the following activities describes the BEST way to formulate acceptance criteria for a given user story?**

**Please choose ONE option! (1 out of 4)**

a)	Performing retrospectives to determine the actual needs of the stakeholders	<input type="checkbox"/>
b)	Using the given/when/then format to describe an example test condition	<input checked="" type="checkbox"/>
c)	Using verbal communication to reduce the risk of misunderstanding the acceptance criteria by others	<input type="checkbox"/>
d)	Documenting risks related to a given user story in a test plan to facilitate the risk-based testing	<input type="checkbox"/>

FL-4.5.2 (K2) Classify the different options for writing acceptance criteria

Justification:

- a) FALSE – Retrospectives are used to gain knowledge and improve the development and testing process, not to document acceptance criteria for a user story.
- b) **CORRECT** – This is a standard method for documenting acceptance criteria for a user story (see CTFL Syllabus V.4.0; Section 4.5.1, 3<sup>rd</sup> paragraph, 1<sup>st</sup> bullet).
- c) FALSE – Oral communication does not allow acceptance criteria to be physically documented as part of a user story ("card" aspect in the 3C model) (see CTFL Syllabus V.4.0; Section 4.5.1, 1<sup>st</sup> paragraph, 1<sup>st</sup> bullet).
- d) FALSE – Acceptance criteria refer to a user story, not to a test plan. Furthermore, acceptance criteria are the conditions that must be met to determine whether the user story is complete. Risks are not such conditions

Question 29	FL-4.5.3	K3	Score 1.0
-------------	----------	----	-----------

Your team is following the Acceptance Test-Driven Development (ATDD) approach and analyzes the following user-story to create test cases.

*As a registered customer, I want to be able to view my past orders on the company's website to keep track of my purchases.*

Your team has identified the following list of test cases. Which of the test cases is NOT relevant to this user-story?

Please choose ONE option! (1 out of 4)

a)	<b>Input:</b> The customer logs into their account on the website and clicks the "View Order History" button. <b>Expected output:</b> The system displays a list of all the customer's previous orders, including date, order number, and total cost.	<input type="checkbox"/>
b)	<b>Input:</b> The logged-in customer clicks on an order in the list of his orders. <b>Expected output:</b> The system displays each purchased item with price and quantity.	<input type="checkbox"/>
c)	<b>Input:</b> The logged-in customer clicks the "Sort Ascending" button on the order history screen. <b>Expected output:</b> The system displays the order history sorted in ascending order by order number.	<input type="checkbox"/>
d)	<b>Input:</b> A newly registered customer logs in and enters a first order. <b>Expected output:</b> The system accepts the order and stores the associated data.	<input checked="" type="checkbox"/>

FL-4.5.3 (K3) Use acceptance test-driven development (ATDD) to derive test cases

Justification: (cf. ISTQB® Certified Tester Syllabus Foundation Level 4.0)

- a) FALSE – The test case matches the user story because it tests an important aspect (customer is a registered customer and has a history) of the user story (see CTFL Syllabus 4.0, section 4.5.3, 4<sup>th</sup> and 5<sup>th</sup> paragraph).
- b) FALSE – The test case matches the user story because it tests a potential aspect (customer should get an overview of his purchases) of the user story (see CTFL Syllabus 4.0, section 4.5.3, 4<sup>th</sup> and 5<sup>th</sup> paragraph).
- c) FALSE – The test case matches the user story because it tests a potential aspect (customer should get an overview of his purchases) of the user story (see CTFL Syllabus 4.0, Section 4.5.3, 4<sup>th</sup> and 5<sup>th</sup> paragraphs).
- d) **CORRECT** – The test case has NO relevance to the user story because a newly registered customer has no order history. The test case may be relevant to an online ordering system in principle, but not to this user story. (see CTFL Syllabus 4.0, section 4.5.3)

Question 30	FL-5.1.2	K1	Score 1.0
-------------	----------	----	-----------

**How do testers add value to iteration and release planning?**

**Please choose ONE option! (1 out of 4)**

a)	Testers determine the priority of the user stories to be developed.	<input type="checkbox"/>
b)	Testers focus only on refining the functional aspects of the system under test.	<input type="checkbox"/>
c)	Testers participate in risk analysis and determine testability of user stories.	<input checked="" type="checkbox"/>
d)	Testers enable the release of high quality software through early test design during release planning.	<input type="checkbox"/>

FL-5.1.2 (K1) Recognize how a tester adds value to iteration and release planning

Justification:

- a) FALSE – The priorities for the user stories are set by the business representative together with the development team.
- b) FALSE – The testers focus on both functional and non-functional aspects of the system under test. (see ISTQB® Foundation Level Syllabus V.4.0; is part of the added value, see 5.1.2 - 3<sup>rd</sup> paragraph, but the 'only' makes it false).
- c) **CORRECT – According to the syllabus, this is one of the ways in which testers add value to iteration planning. (see ISTQB® Foundation Level Syllabus V.4.0; Section 5.1.2, 3<sup>rd</sup> paragraph, 2<sup>nd</sup> sentence).**
- d) FALSE – Early test design is not part of release planning and certainly not during release planning - contradiction in terms (see ISTQB® Foundation Level Syllabus V.4.0; Section 5.1.2, 2<sup>nd</sup> paragraph).



Question 31	FL-5.1.3	K2	Score 1.0
-------------	----------	----	-----------

**Which ONE of the following options is an exit criterion for testing a system?**

**Please choose ONE option! (1 out of 4)**

a)	Test environment readiness	<input type="checkbox"/>
b)	The ability to log in to the test object by the tester	<input type="checkbox"/>
c)	Expected defect density is reached and defects are reported	<input checked="" type="checkbox"/>
d)	Requirements are translated into given/when/then format	<input type="checkbox"/>

FL-5.1.3 (K2) Compare and contrast entry criteria and exit criteria

Justification:

- a) FALSE – Test environment readiness is a resource availability criterion; hence it belongs to the entry criteria (cf. CTFL Syllabus V.4.0; Section 5.1.3, 2<sup>nd</sup> paragraph).
- b) FALSE – This is a resource availability criterion; hence it belongs to the entry criteria (cf. CTFL Syllabus V.4.0; Section 5.1.3, 2<sup>nd</sup> paragraph).
- c) **CORRECT – Estimated defect density is a measure of diligence; hence it belongs to the exit criteria. The complete reporting of all defects found in the test is also a closure criterion and therefore also belongs to the exit criteria. The peculiarity here is that two defined exit criteria are linked. (cf. CTFL syllabus V.4.0; section 5.1.3, 3<sup>rd</sup> paragraph).**
- d) FALSE – Requirements translated into a given format result in testable requirements; hence it belongs to the entry criteria (cf. CTFL Syllabus V.4.0; Section 5.1.3, 2<sup>nd</sup> paragraph).

Question 32	FL-5.1.4	K3	Score 1.0
-------------	----------	----	-----------

Your team uses the three-point estimation technique to estimate the test effort for a new high-risk feature. The following estimates were made:

- most optimistic estimation: 2 person-hours
- most likely estimation: 11 person-hours
- most pessimistic estimation: 14 person-hours

What is the final estimate?

Please choose ONE option! (1 out of 4)

a)	9 person-hours	<input type="checkbox"/>
b)	10 person-hours	<input checked="" type="checkbox"/>
c)	11 person-hours	<input type="checkbox"/>
d)	14 person-hours	<input type="checkbox"/>

FL-5.1.4 (K3) Use estimation techniques to calculate the required test effort

Justification:

In the three-point estimation technique

$E = (\text{most optimistic} + 4 \cdot \text{most likely} + \text{most pessimistic}) / 6,$

$E = (2 + (4 \cdot 11) + 14) / 6 = 10.$

Hence b) is CORRECT.

Question 33	FL-5.1.5	K3	Score 1.0
-------------	----------	----	-----------

You are testing a mobile application that allows users to find a nearby restaurant based on the type of food they want to eat. Consider the following list of test cases, priorities (i. e., a smaller number means a higher priority), and dependencies:

Test case number	Test condition covered	Priority	Logical dependency on
TC 001	Select type of food	3	none
TC 002	Select restaurant	2	TC 001
TC 003	Get directions	1	TC 002
TC 004	Call restaurant	2	TC 002
TC 005	Make reservation	3	TC 002

Which of the following test cases should be executed as the third one?

Please choose ONE option! (1 out of 4)

a)	TC 003	<input checked="" type="checkbox"/>
b)	TC 005	<input type="checkbox"/>
c)	TC 002	<input type="checkbox"/>
d)	TC 001	<input type="checkbox"/>

FL-5.1.5 (K3) Apply test case prioritization

Justification:

Test TC 001 must come first, followed by TC 002, to satisfy dependencies. Afterwards, TC 003 to satisfy priority and then TC 004, followed by TC 005.

a) CORRECT.

b) FALSE.

c) FALSE.

d) FALSE.

Question 34	FL-5.1.7	K2	Score	1.0
-------------	----------	----	-------	-----

Consider the following tests (1-4) and testing quadrants (A-D):

1. Usability testing
  2. Component testing
  3. Functional testing
  4. Reliability testing
- 
- A. Testing quadrant Q1: technology facing, supporting the team
  - B. Testing quadrant Q2: business facing, supporting the team
  - C. Testing quadrant Q3: business facing, critical consideration of the product
  - D. Testing quadrant Q4: technology facing, critical consideration of the product

How do the following test categories map onto the testing quadrants?

Please choose ONE option! (1 out of 4)

a)	1C, 2A, 3B, 4D	<input checked="" type="checkbox"/>
b)	1D, 2A, 3C, 4B	<input type="checkbox"/>
c)	1C, 2B, 3D, 4A	<input type="checkbox"/>
d)	1D, 2B, 3C, 4A	<input type="checkbox"/>

FL-5.1.7 (K2) Summarize the testing quadrants and their relationships with test levels and test types

Justification:

Usability testing is in Q3 (1 – C)  
Component testing is in Q1 (2 – A)  
Functional testing is in Q2 (3 – B)  
Reliability testing is in Q4 (4 – D)

Hence a) is CORRECT.

Question 35	FL-5.2.4	K2	Score	1.0
-------------	----------	----	-------	-----

During a risk analysis the following risk was identified and assessed:

- Risk: Search result response time is too long
- Risk likelihood: medium; risk impact: high
- Response to risk:
  - an independent test team performs performance testing during system testing
  - a selected sample of end users performs alpha and beta acceptance testing before the release

What kind of actions were proposed above to respond to the identified risk?

Please choose ONE option! (1 out of 4)

a)	Risk acceptance	<input type="checkbox"/>
b)	Contingency plan	<input type="checkbox"/>
c)	Risk mitigation	<input checked="" type="checkbox"/>
d)	Risk transfer	<input type="checkbox"/>

FL-5.2.4 (K2) Explain what measures can be taken in response to analyzed product risks

Justification:

- a) FALSE – The risk is not accepted; concrete actions are proposed
- b) FALSE – No contingency plans are proposed
- c) CORRECT – The proposed actions are related to testing, which is a form of risk mitigation (See CTFL Syllabus V.4.0; Section 5.1.7, latest bullet point list).
- d) FALSE – The risk is not transferred but mitigated

Question 36	FL-5.3.2	K2	Score 1.0
-------------	----------	----	-----------

**Which of the following statements about the purpose and content of test reports is true?**

**Please choose ONE option! (1 out of 4)**

a)	Test completion reports are prepared and distributed on a regular basis to keep stakeholders up to date on progress.	<input type="checkbox"/>
b)	A test progress report includes, among other things, an assessment of the quality of the product and any deviations from the schedule.	<input type="checkbox"/>
c)	A test completion report is generated when a test level has been completed and builds on test progress reports and additional data.	<input checked="" type="checkbox"/>
d)	Test progress reports are generated during test completion to demonstrate that the exit criteria have been met.	<input type="checkbox"/>

FL-5.3.2 (K2) Summarize the purposes, content, and audiences for test reports

Justification: (see. ISTQB® CTFL Syllabus 4.0)

- a) FALSE – because test completion reports are not generated periodically for any purpose; these are test progress reports. (See clause 4.0, section 5.3.2, paragraph 2).
- b) FALSE – because this is typical test completion report information. (See syllabus 4.0, section 5.3.2, paragraph 3, list items 2 and 3).
- c) **CORRECT** – because test completion reports are created and distributed at times when substantially similar tasks have been completed, e. g., a project, a test level, a test type, an iteration, etc. (see Syllabus 4.0, Section 5.3.2, paragraph 1, last sentence; paragraph 3).
- d) FALSE – because test progress reports are generated continuously during test monitoring and control, whereas test completion reports are generated at test completion. In addition, the test completion report documents that the exit criteria have been met (see clause 4.0, section 5.3.2, paragraph 3).

Question 37	FL-5.4.1	K2	Score 1.0
-------------	----------	----	-----------

You need to update one of the automated test scripts to align with a new requirement.

Which process indicates that a new version of the test script should added to the test repository?

Please choose **ONE** option! (1 out of 4)

a)	Traceability management	<input type="checkbox"/>
b)	Maintenance testing	<input type="checkbox"/>
c)	Configuration management	<input checked="" type="checkbox"/>
d)	Requirements management	<input type="checkbox"/>

FL-5.4.1 (K2) Summarize how configuration management supports testing

Justification:

- a) FALSE – Traceability is the relationship between two or more work products, not between different versions of the same work product.
- b) FALSE – Maintenance testing is about testing changes; it is not related closely to versioning.
- c) **CORRECT** – To support testing, configuration management may involve the version control of all test items (see CTFL Level Syllabus V.4.0; Section 5.4, 4<sup>th</sup> paragraph, 1<sup>st</sup> sentence).
- d) FALSE – Requirements engineering is the elicitation, documentation, and management of requirements; it is not closely related to test script versioning.

Question 38	FL-5.5.1	K3	Score 1.0
-------------	----------	----	-----------

In your role as project lead, you received the following defect report from the developers stating that the anomaly described is not reproducible.

*Application hangs up*

*ID 713-20230401 2022-May-03 – John Doe – Rejected*

*The application hangs up after entering "Test input: \$ä" in the Name field on the new user creation screen. I tried logging out and logging in with test\_admin01 account, same problem. Tried with other test administrator accounts, same problem. No defect message received; the log (see attachment) contains a fatal defect message. Based on test case TC-1305, the application should accept the provided input and create the user. Please fix this issue with high priority as this feature is related to REQ-0012 which is an important new functional requirement.*

What important information is **MISSING** from this test report that would have been useful for the developers?

Please choose **ONE** option! (1 out of 4)

a)	Expected result and actual result	<input type="checkbox"/>
b)	References and defect status	<input type="checkbox"/>
c)	Test environment and test item	<input checked="" type="checkbox"/>
d)	Priority and severity (incl. version)	<input type="checkbox"/>



FL-5.5.1 (K3) Prepare a defect report

Justification:

- a) FALSE – Expected result and actual result. The expected result is "The application should accept the input and create the user". The actual result is "The application hangs after typing "Test input: \$ä"". So both are present.
- b) FALSE – references and state. There is a reference to the test case and its associated requirement, and the defect is rejected. So both are present.
- c) CORRECT – Test environment and test item. We do not know in which test environment the anomaly was found, nor do we know which test object or application (and which version) is involved. (see ISTQB® Foundation Level Syllabus V.4.0; Section 5.5, 3<sup>rd</sup> paragraph, 3<sup>rd</sup> bullet).
- d) FALSE – Priority and severity. The defect report states that the anomaly is urgent, that it is a common problem (i. e. many if not all test administration accounts are affected), and that the impact on business stakeholders is high. So both are covered.

Question 39	FL-6.1.1	K2	Score 1.0
-------------	----------	----	-----------

**Which test activity does a data preparation tool support?**

**Please choose ONE option! (1 out of 4)**

a)	Test monitoring and control	<input type="checkbox"/>
b)	Test analysis and design	<input type="checkbox"/>
c)	Test implementation and execution	<input checked="" type="checkbox"/>
d)	Test completion	<input type="checkbox"/>

FL-6.1.1 (K2) Explain how different types of test tools support testing

Justification:

- a) FALSE – Test monitoring involves the ongoing checking of all activities and comparison of actual progress against the test plan. Test control involves taking the actions necessary to meet the test objectives of the test plan. No test data are prepared during these activities.
- b) FALSE – Test analysis involves analyzing the test base to identify and prioritize test conditions. Test design involves the creation of test conditions in the form of test cases and other testware. Test data requirements are defined and created during implementation.
- c) **CORRECT – Test design and implementation tools - facilitate the creation of test cases, test data, and test runs. (cf. CTFL Syllabus V.4.0; Section 6.1, 3<sup>rd</sup> bullet point).**
- d) FALSE – Test completion activities occur at project milestones (e. g., release, end of iteration, test level completion), so it is too late for preparing test data

Question 40	FL-6.2.1	K1	Score 1.0
-------------	----------	----	-----------

Which item correctly identifies a potential risk with test automation?

Please choose ONE option! (1 out of 4)

a)	There may be unknown side effects in operational use	<input type="checkbox"/>
b)	Unrealistic expectations regarding functionality of a tool	<input checked="" type="checkbox"/>
c)	Test tools may not be reliable enough	<input type="checkbox"/>
d)	The amount of time that is available for manual testing may be reduced in the long run	<input type="checkbox"/>

FL-6.2.1 (K1) Recall the benefits and risks of test automation

Justification:

- a) FALSE – Test automation does not lead to unknown side-effects when used in an operational environment.
- b) CORRECT – The unrealistic expectation is that in some cases management believes that the introduction of a test tool will solve all problems. (See CTFL Syllabus V.4.0; Section 6.2, Test Automation, 1<sup>st</sup> bullet).**
- c) FALSE – Test tools must be selected so that they can be relied upon.
- d) FALSE – Implementing test automation can reduce the resources needed for manual testing in the interim. In the long run, saving time is a benefit of test automation. So, this is a benefit, not a risk.

**Space for your notes:**

(are neither read nor valuated during correction)

**Space for your notes:**

(are neither read nor valuated during correction)

**Space for your notes:**

(are neither read nor valuated during correction)

**Space for your notes:**

(are neither read nor valuated during correction)